

BURNT IS THE NEW BLACK

***ZAPÁLENÝ SPORTOVEC**

Kontrast

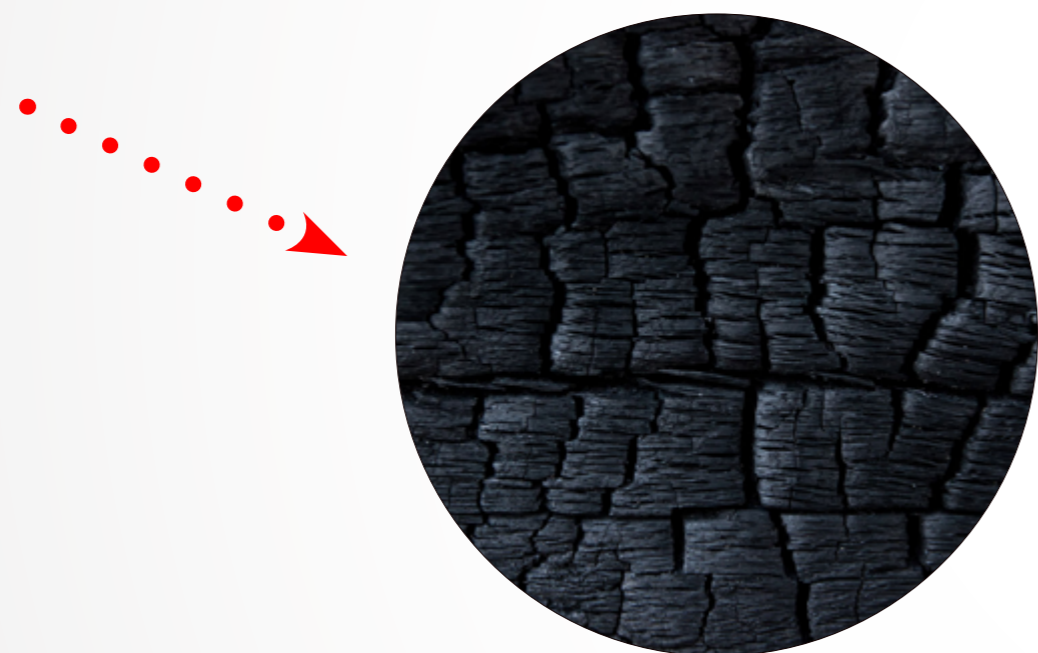

1) Kontrast textury



2) Funkce / Hra

Objekt / Hračka

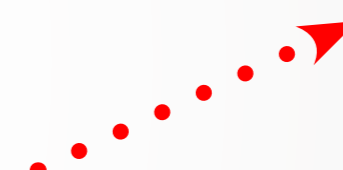

Myšlenka

2.

1) Chápaní, jako předmětu za
jedním účelem

2) Materiálová stránka

3) Zajímavý objekt do interiéru

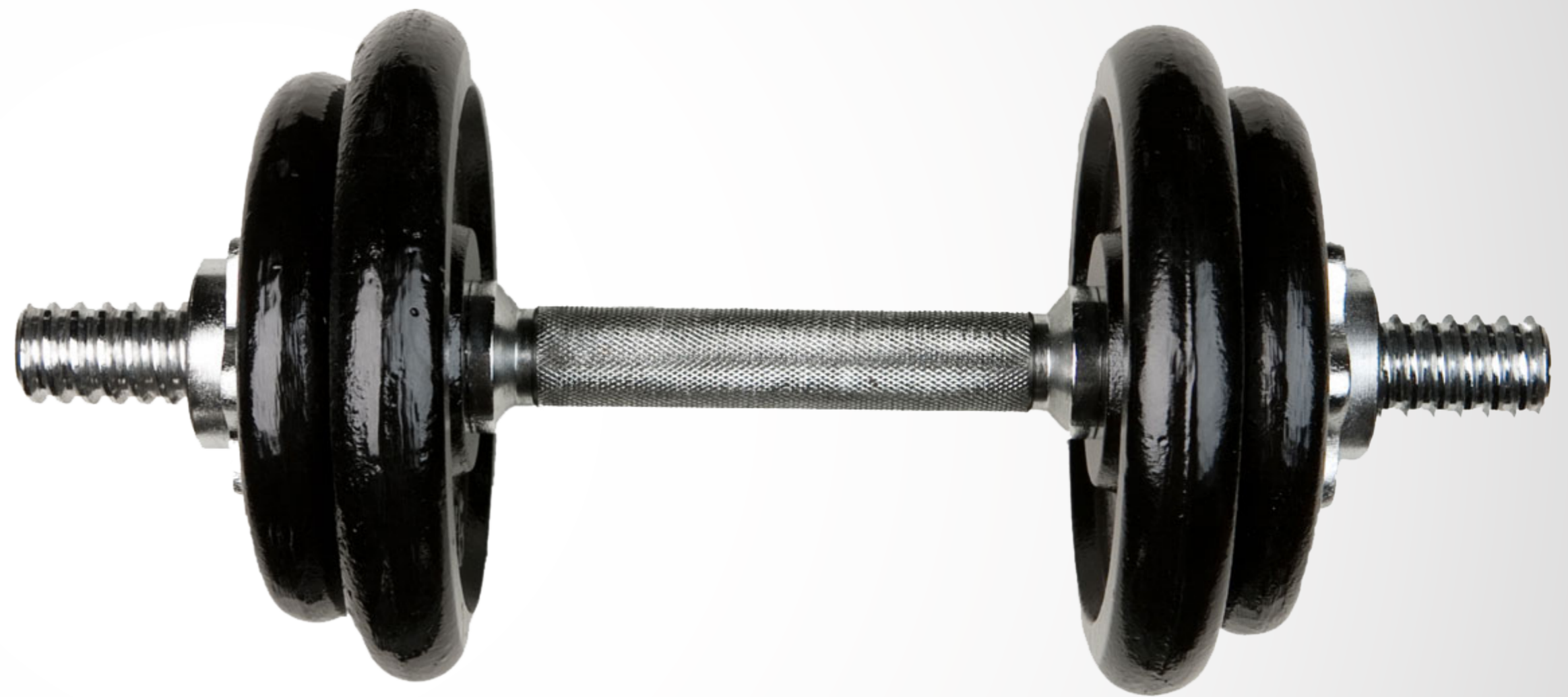

Proč činka?

3.

Vzor: práce Jana Čapka

1) Vytvořit umělecký
funkční objekt





Činka – dospělácká hračka



1)

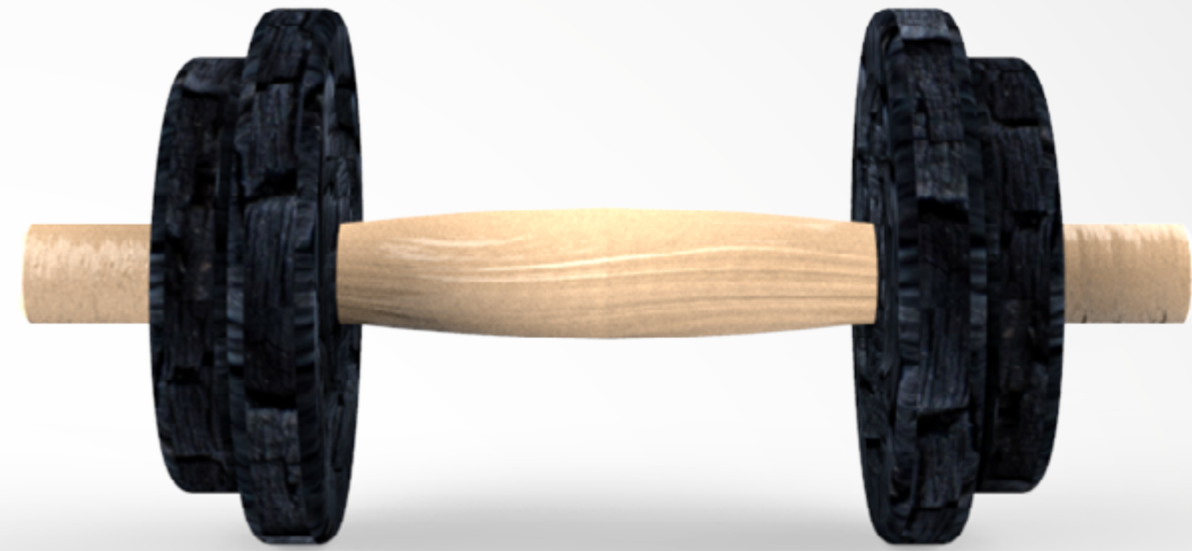

2)

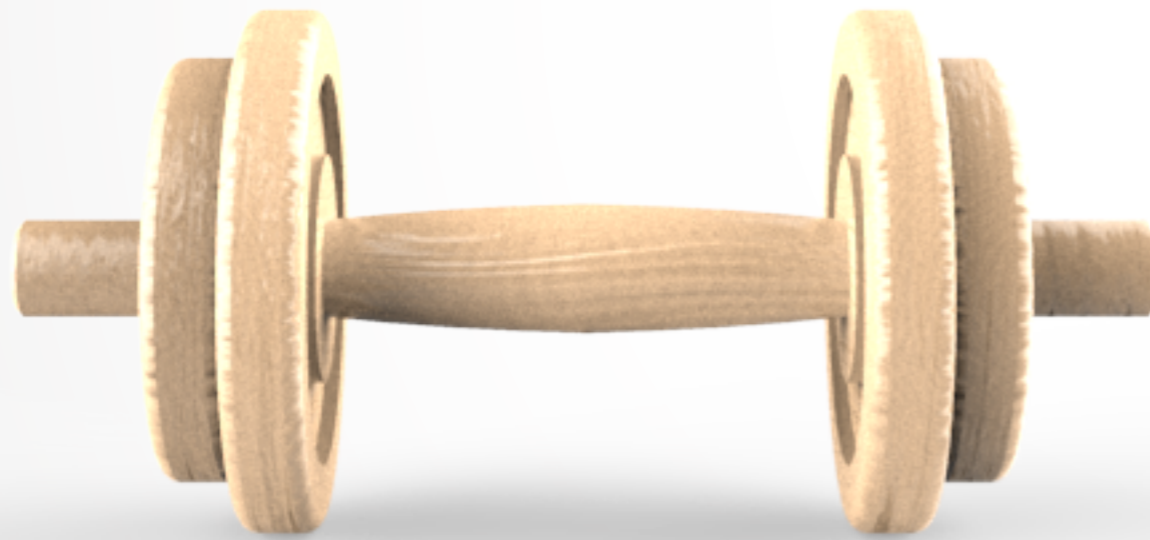

3)



4)

Varianty

6.

1) Rukojeť

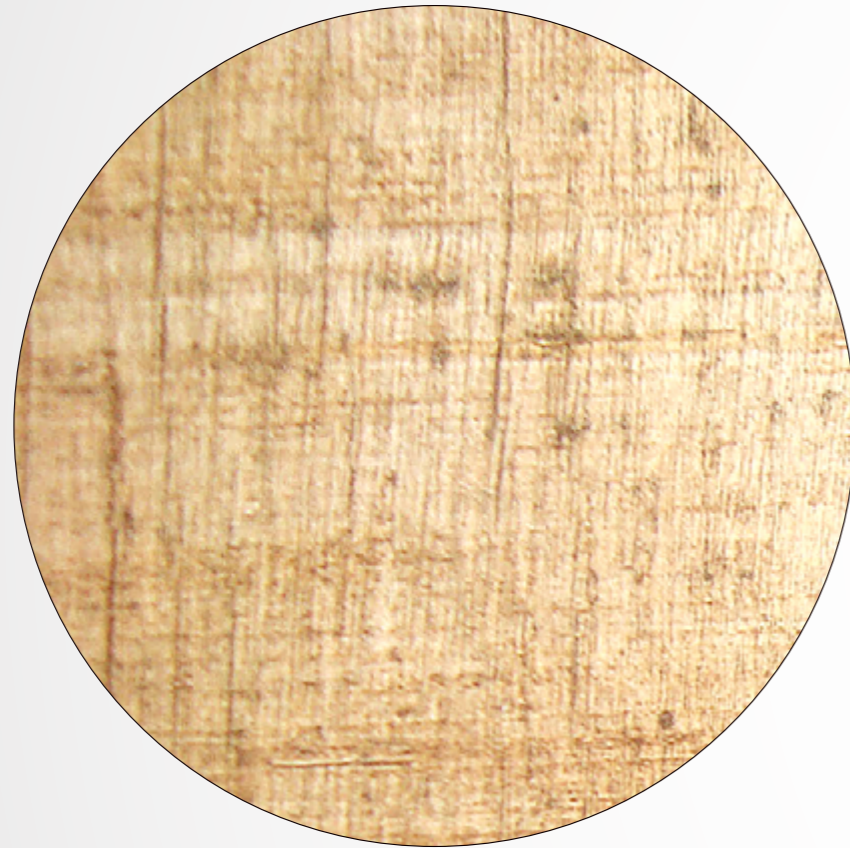

Příjemná na dotek

2) Rukojeť



Antibakteriální

3) Komplet



Hravý

Funkce

1) Nařezání základních tvarů



2) Soustružení



3) Sestavení a opálení plamenem



Postup výroby

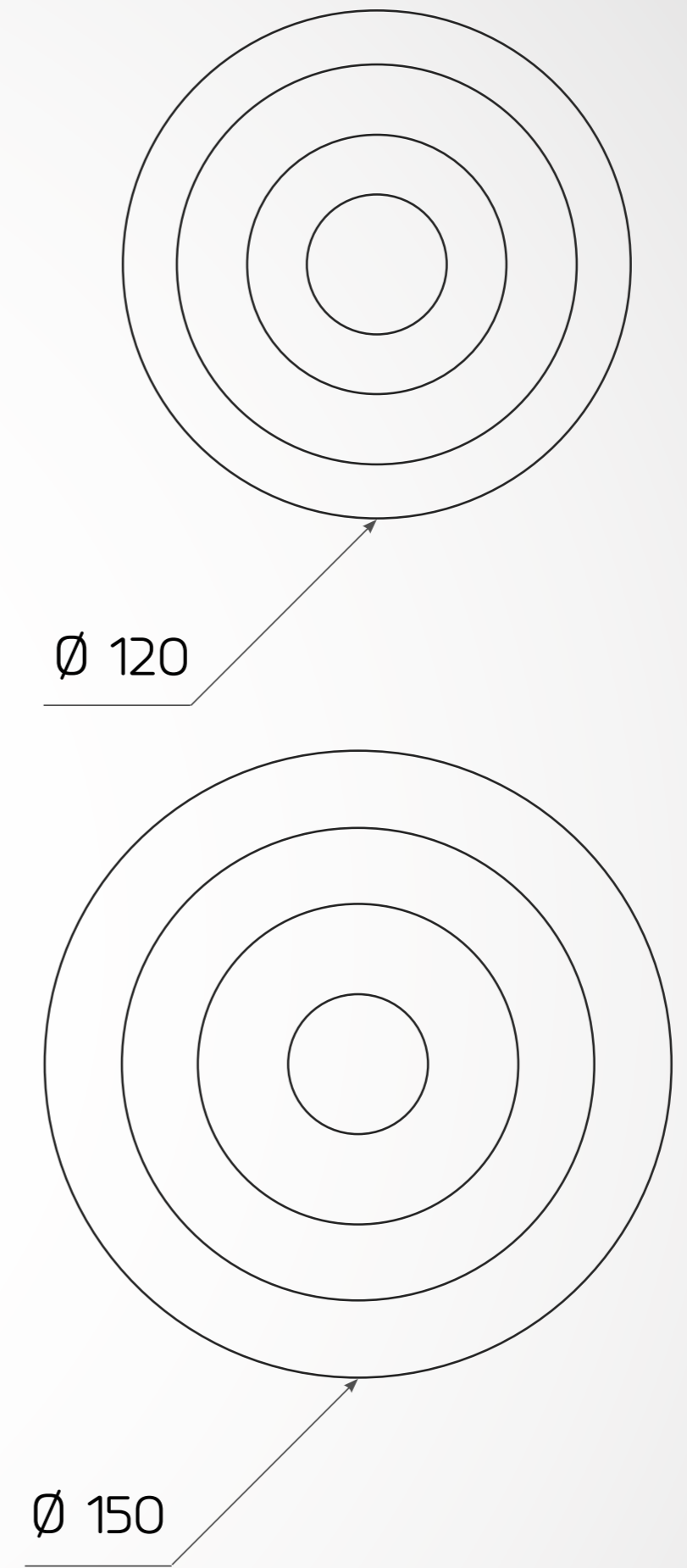
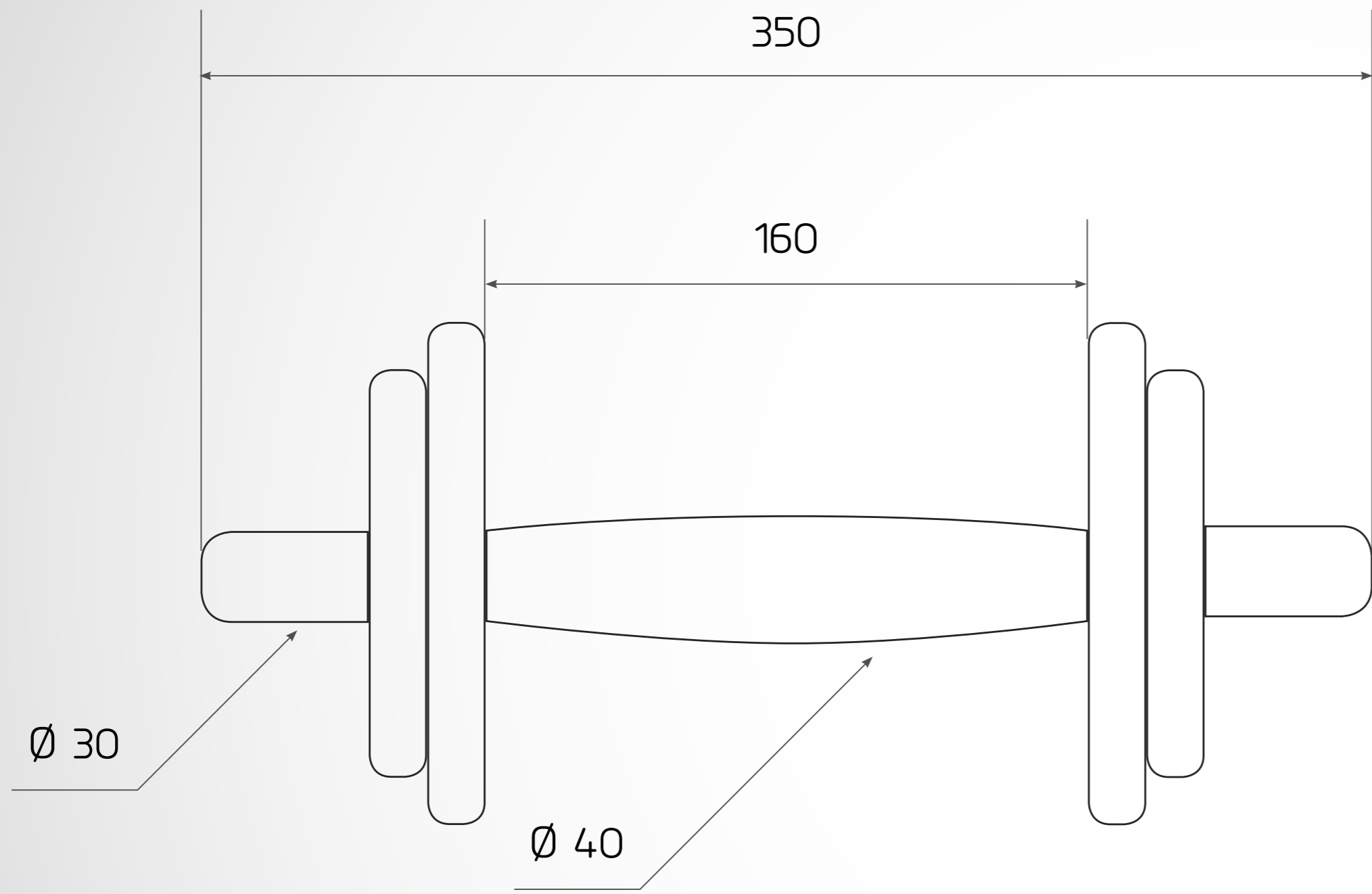

*ZAPÁLENÝ SPORTOVEC

Pasecký Jiří / Ateliér 3D design / 2015